

Description

A magnetic SMD buzzer is an electronic device that produces a sound when an electrical signal is applied to it. The function of a magnetic buzzer is to provide an audible alert or notification in various electronic devices such as alarms, timers, and electronic toys. The buzzer consists of a coil of wire and a magnet that vibrate when an alternating current is passed through the coil.

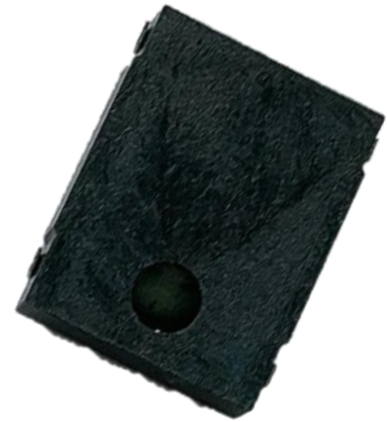

Applications

- Electronic devices
- Industrial and commercial equipment
- Home appliances
- Toys and games
- Sound effects
- Audio Alerts
- Warning Signals
- Audio Feedback

Features

Item	Specification	Unit	Condition
Oscillation frequency	2730	Hz	
Operating voltage	3~7	Vdc	
Rated voltage	5	Vdc	
Current consumption	MAX.60	mA	at Rated Voltage
Sound pressure level	MIN.91	dB	at 10cm at Rated Voltage
Operating temperature	-40~ +85	°C	

Buzzer, Magnetic

SB050PM-141135-S91

Storage temperature	-40 ~ +85	°C	
Dimension	14.8 x 11.0 x 3.5	mm	See appearance drawing
Housing material	LCP(Black)		
Leading pin	Tin plated Brass		See appearance drawing
Certifications	RoHS		

Appearance drawing

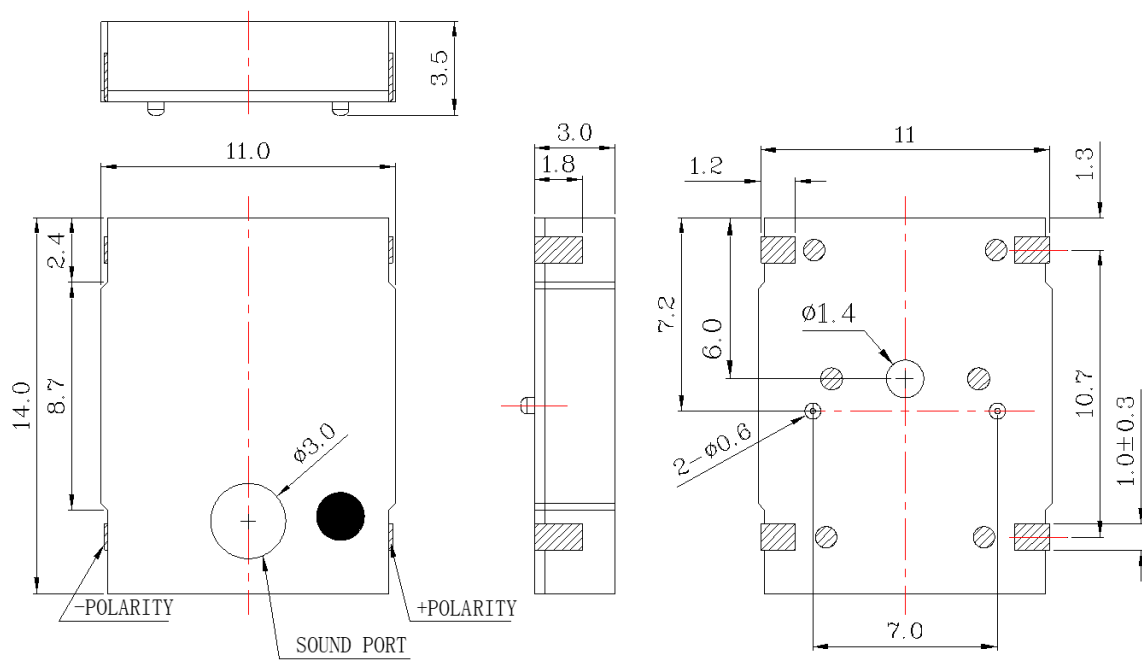

Tol : ± 0.3 Unit: mm

Buzzer, Magnetic

SB050PM-141135-S91



Testing method

Standard Measurement conditions

Temperature:	25±2°C
Humidity:	45-65%

Acoustic Characteristics

The oscillation frequency, current consumption and sound pressure are measured by the measuring instruments at 10 cm

Typical Frequency Response Curve

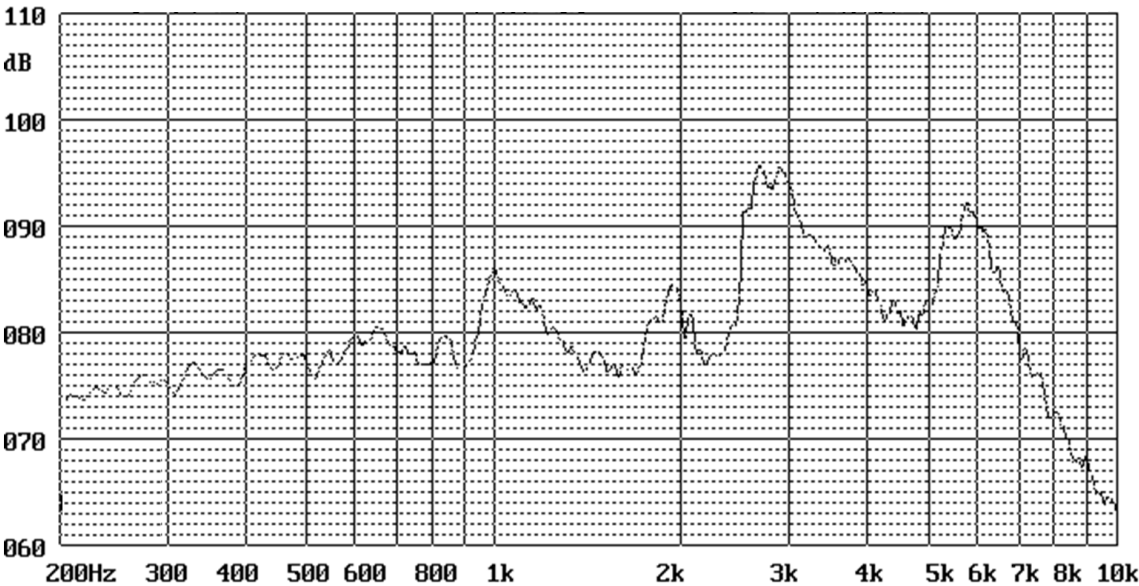

Recommended Driving Circuit

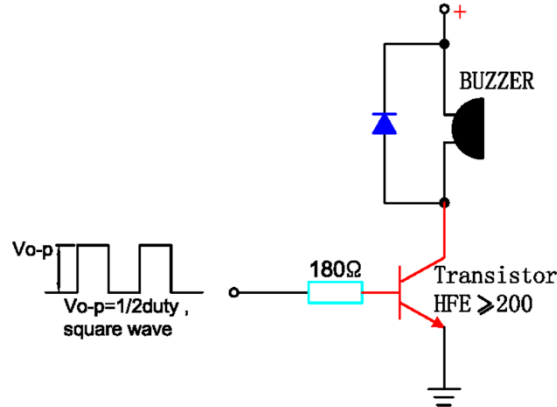

The base current I_b should be high enough so that it saturates the collector current of the transistor with the CB Load

Reliability test

Item	Test condition and requirement
High Temperature Test (Storage)	After being placed in a chamber with $85\pm 2^\circ\text{C}$ for 96 hours and then being placed in normal condition for 2 hours. Allowable variation of SPL after test: $\pm 10\text{dB}$.
Low Temperature Test (Storage)	After being Placed in a chamber with $-40\pm 2^\circ\text{C}$ for 96 hours and then being placed in normal condition for 2 hours. Allowable variation of SPL after test: $\pm 10\text{dB}$.
Humidity Test	After being Placed in a chamber with 90-95% R.H. at $40\pm 2^\circ\text{C}$ for 96 hours and then being placed in normal condition for 2 hours. Allowable variation of SPL after test: $\pm 10\text{dB}$.

Temperature Cycle

Test

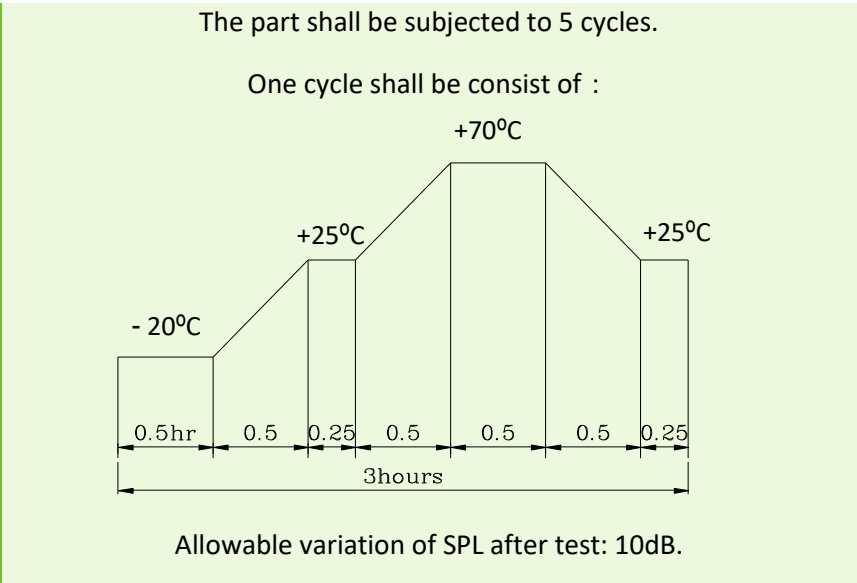

Drop Test

Drop on a hard wood board of 4cm thick, any directions ,6 times, at the height of 75cm. Allowable variation of SPL after test: ± 10 dB.

Vibration Test

After being applied vibration of amplitude of 1.5mm with 10 to 55 Hz band of vibration frequency to each of 3 perpendicular directions for 2 hours. Allowable variation of SPL after test: ± 10 dB.

Solderability

Test

Lead terminals are immersed in rosin for 5 seconds and then immersed in solder bath of $+300 \pm 5^\circ\text{C}$ for 3 ± 1 seconds. 90% min. lead terminals shall be wet with solder (Except the edge of terminals).

Terminal Strength

Pulling Test

The force of 9.8N(1.0kg) is applied to each terminal in axial direction for 10 seconds. No visible damage and cutting off.

Test condition

Standard Test Condition

Temperature:	+5 ~ +35°C
Humidity:	45 - 85%
Pressure:	860 – 1060 mbar

Buzzer, Magnetic

SB050PM-141135-S91

Judgment Test Condition

Temperature:	+25 ± 2°C
Humidity:	60 - 70%
Pressure:	860 - 1060mbar

Package

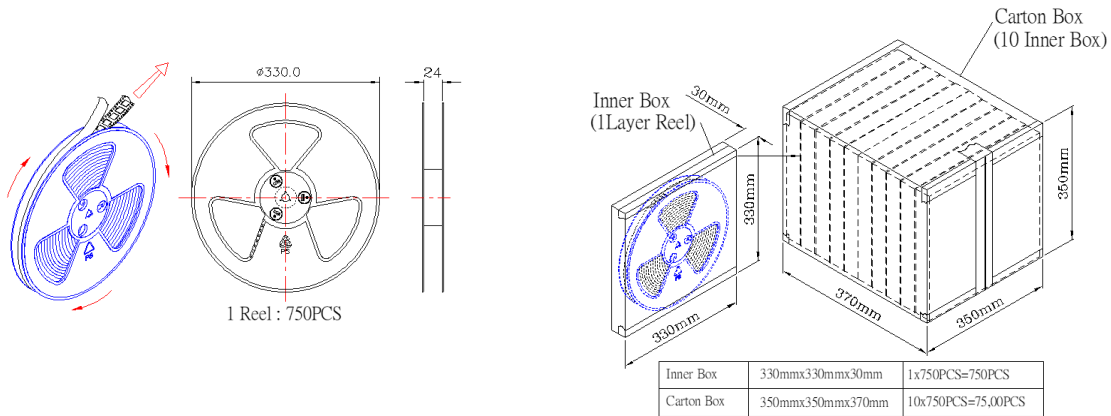

Part number

SBXXXXX-XXX-XX

SB	Buzzer
XXX	Rated power
X	Passive / Active
X	Piezo / Magnetic
XXXXX	Size
X	THT / SMD
XX	dB @ rated power

Ordering information

Ordering can be done via www.summit-electronics.com or via info@summit-electronics.com. Please contact us for more information. Customisation of the product is available on request.

Technical support

For all product questions please contact us via info@summit-electronics.com

Document revision

Rev	Date	changes
V01.00	10-06-2023	First issue of document